

# OPERATING MANUAL FOR MPD MODEL : S-DXC / 0.8 TO 5 A

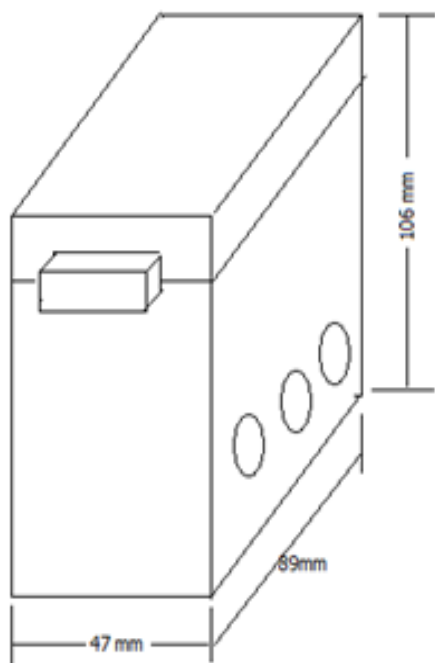

## Dimension for Controller cum CT Unit

## Dimension for Display cum Keypad Unit

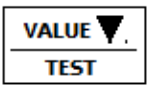
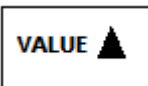
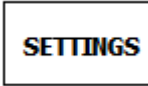

**Note: Length of FRC Available is 1 meter OR 2 meter.**

### Functions of Keys :

	To reduce values during setting of parameters & to TEST the RELAY contact when no current is passing through device.
	To increase values during setting of parameter.
	To enter in setting of paramters
	To reset the device after trip during falult occur.

## Mounting of Display on Panel Door (Door Cutout : 70 X 30 mm)

### Step : 1

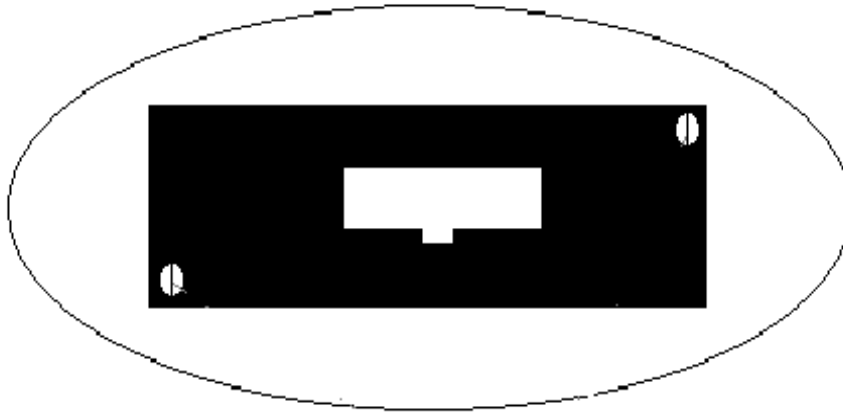

### Step : 2

#### Rear view of LED Display

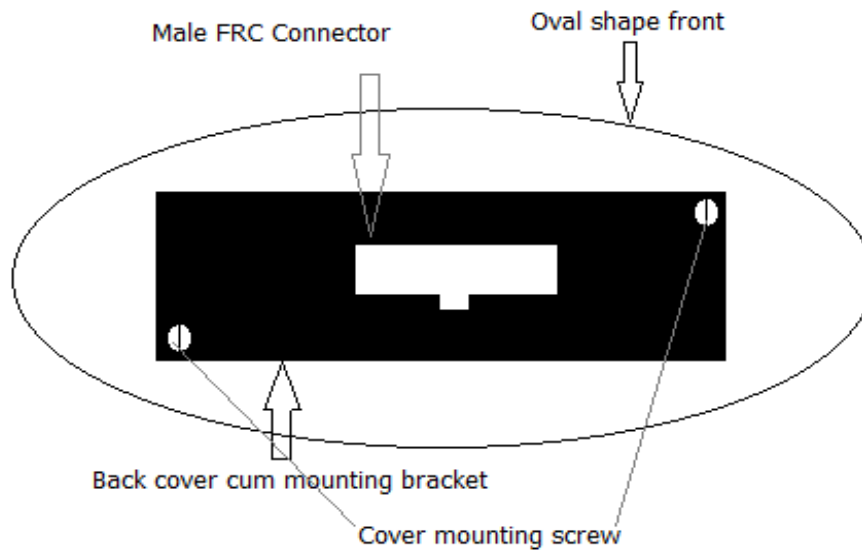

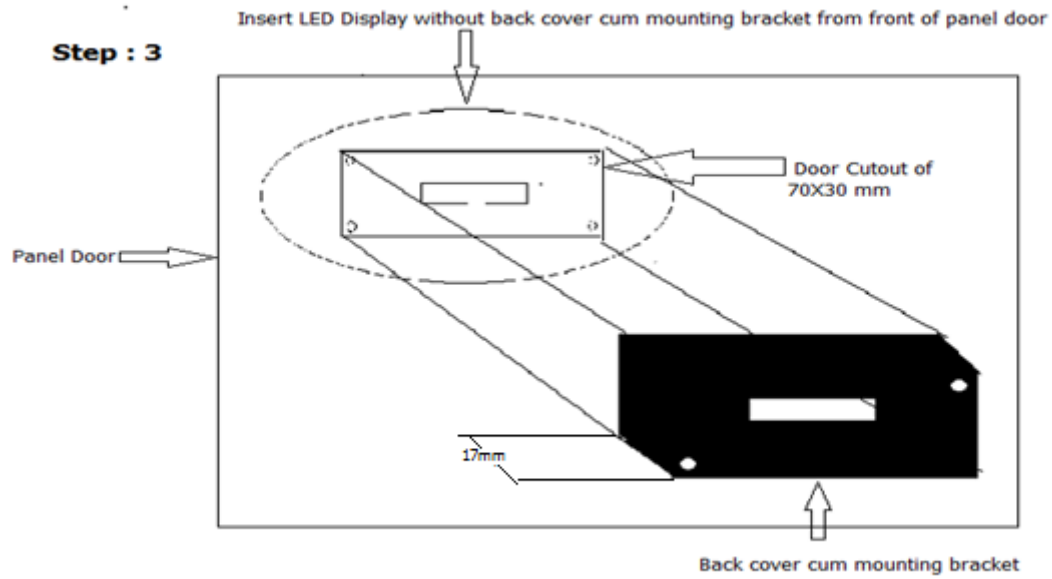

**Step : 4** Mounting of Display on door

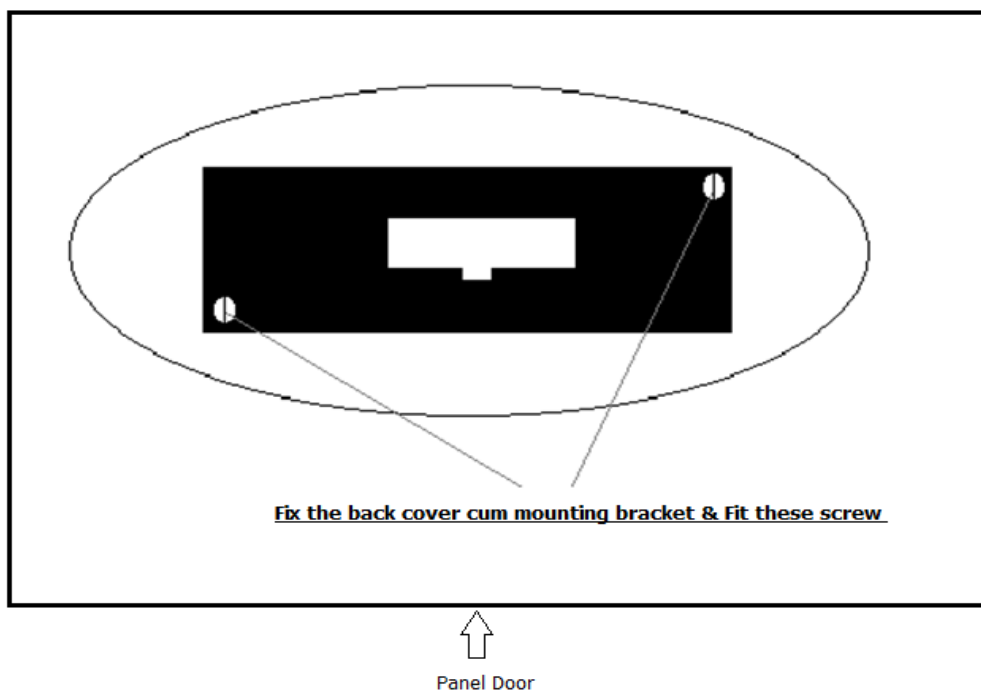

## List of Parameter for MPD Model: S-DXC / 0.8 – 5 Amp

Sr. No.	Parameter Name/Meaning	Settable Value	Password
01.	Set Current [ <b>S</b> ] / FLC of Motor	0.8 TO 5 Amp	Fact / Engg
02.	Under Current [ <b>U</b> ]/ No Load Current of Motor	0 TO 4.0 Amp	Fact / Engg
03.	Set Earth Fault Current [ <b>E</b> ]	0.1 TO 25.0 Amp	Fact / Engg
04.	Over Load Curve [ <b>C</b> ] *	0/5/10/15/20/2 Sec	Engineering
05.	SPP Trip Time [ <b>P</b> ]	3 TO 20 Sec.	Engineering
06.	Under Load Trip Time [ <b>L</b> ]	6 TO 30 Sec,	Engineering
07.	Calibration [ <b>E•</b> ] / OFFSET of R Phase	±1.0 Amp	Fact / Engg
08.	Calibration [ <b>E•</b> ] / OFFSET of Y Phase	±1.0 Amp	Fact / Engg
09.	Calibration [ <b>E•</b> ] / OFFSET of B Phase	±1.0 Amp	Fact / Engg
10.	Scrolling Time [ <b>t</b> ] / Time interval for scrolling	0 To 10 Second (1)	Fact / Engg
11.	Phase Reversal [ <b>Ph-E</b> ] [ <b>Ph-d</b> ] (2)	Enable/Disable	Fact / Engg
12.	Auto Reset [ <b>Rr-E</b> ] [ <b>Rr-d</b> ](3)	Enable/Disable	Fact / Engg
13.	Lock Rotor Value [ <b>r</b> ]	3 TO 20 Times	Engineering
14.	Definite Time [ <b>d</b> ]	2 TO 900 Sec	Engineering

- (1) Scroll Time 0 : Only one Phase Current indication & Selected Phase by [VALUE ^] Key
- (2) If **Ph-r** fault is present & if Phase Reversal is Enable (**Ph-E**) then MPD trip on **Ph-r** automatically. If it is disable (**Ph-d**) then MPD will not trip on **Ph-r**.
- (3) If Auto Reset is 'Enable' [**Rr-E**] then MPD Reset automatically after 10 minutes. If it is disable [**Rr-d**] then MPD Reset manually by pressing **RESET** key.
- (4) \* When Parameter [**C**] set to 0, motor trips at Overload condition as per Setting of Definite Time [**d**] & IT Curve will be disable

### Password:

There are two PASSWORDS to protect parameters from authorized changes.

- A) Factory Password – Set **P 106** & then Press **PARA** key
- B) Engineering. Password – Set **P 147** & then Press **PARA** key

### Setting of Parameter:

Step: 1

Press **SETTING** button on Keypad, Display will show **P 100**

Step: 2

Press **VALUE** ^ till **P 106**

Step: 3

Press **SETTING** button, then display will show Parameter as per above Table.

Step 4:

Change required value for particular para by Key **VALUE** ^ OR **VALUE** v till desire value.

Step 5:

Press **SETTING** button to go to next para OR leave the key pad. Last data changed will save automatically.

## **RUN Display**

In Normal Running condition Display will show Three Phase Current in Scrolling manner as Scroll Time has been set.

<b>Display</b>	<b>Meaning</b>
• 1.5	Current in R Phase : 1.5 Amp
• 1.8	Current in Y Phase : 1.8 Amp
• 1.3	Current in B Phase : 1.3 Amp

## **TRIPPING & FAULT MESSAGE**

### **OVERLOAD:**

If any phase current (R, Y, B) > Set Current [5] then MPD will trip on Over Load & indicates [a] with indication of the phase which draws highest current & that current value. Trip time will be according to settable O/L Curve (See page- IT CHARECTERISTICS) OR Settable Definite time (See page-Definite Time).

### **UNBALANCE:**

If difference between any two phase current > (Set Current/ 3) then MPD will trip on Unbalance & display show [b] with indication of two phase which are unbalance with value of unbalance current.

### **SINGLE PHASE PROTECTION:**

If anyone phase, out of R, Y, B is absent or OFF then MPD will trip on Single Phase according to SPP Trip time [P] & display will shows [5PP] with indication of phase which sense '0' current.

### **PHASE REVERSE:**

If any two phase (R, Y & B) are interchanged then MPD will trip on phase reversal and display will show [Ph-r]

### **UNDERLOAD:**

If all 3 phases values (R, Y, B) are < Under load Current then MPD will trip on under load according to Under Load Trip Time [L] and display will show [u] with indication of the phase which draws highest current out of three phase but lower than value of Under load set point & that current value.

### **LOCK ROTOR:**

If anyone phase current (R, Y, B) > SET O/L CUR x Lock Rotor Value [r], then MPD will trip on Lock Rotor. Display will show [L] & shows maximum current and the phase in which maximum current flows also indicate with the help of 'LED indication'.

### **SHORT CKT:**

If anyone phase current (R, Y, B) > SET OL CUR x Lock Rotor Value + 1 count [r]+1, then MPD will trip on Short Ckt. & Display will show [5] & shows maximum current and the phase in which maximum current flows also indicate with the help of 'LED indication'.

### **EARTH FAULT:**

If Earth current [E] > SET EARTH CURRENT [E] then MPD will trip on Earth Fault & display will show [E] & shows recent earth leakage current.

 **Advanced Microtech**

Dev Chambers, 2<sup>nd</sup> Floor  
Near Vasant Cinema,  
Cinema Road,  
SURAT – 395003  
Gujarat INDIA

Phone: +91 261 2427320  
+91 261 2411283  
E-mail: amtpower@gmail.com

## Wiring Diagram of MPD Model: S-DXA/0.8-5 Amp

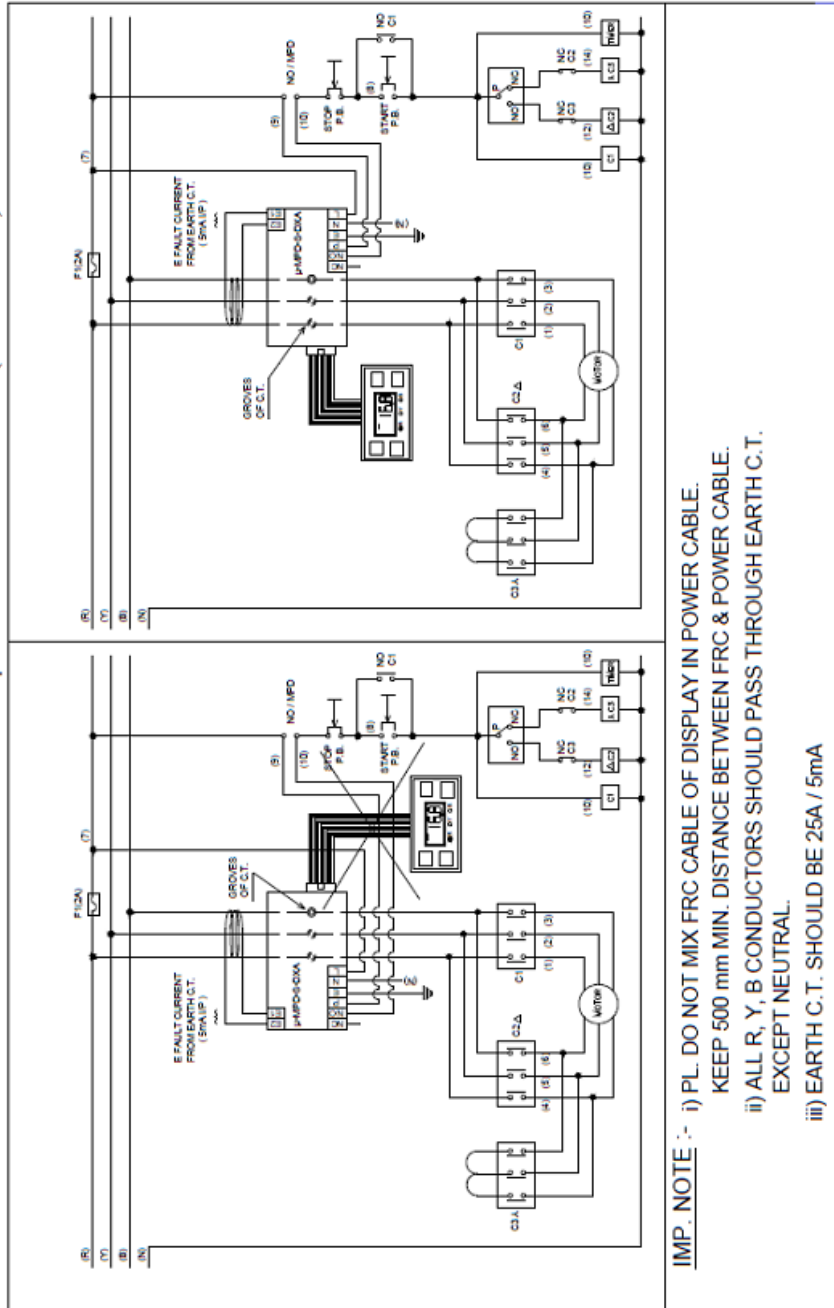

## IT Characteristics for Over Load Trip Time

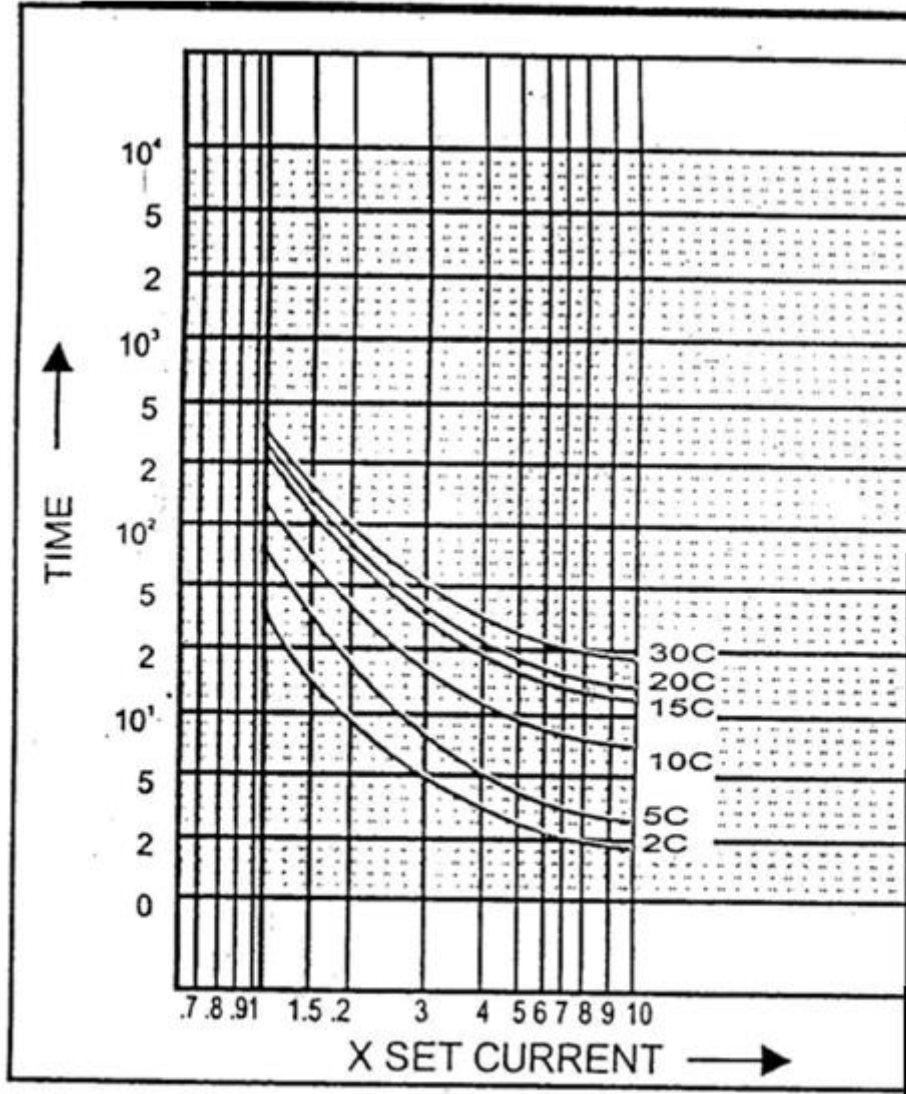

## Definite Time Characteristics for Over Load Trip Time

