



Operating Manual : i.MWM

Current Range : 40 to 500Amp

---





- FRONT VIEW (DISPLAY & KEY BOARD)



**BACK VIEW (CONTROL TERMINAL)**

⊕	⊕	⊕	⊕	⊕	⊕	⊕	⊕	⊕	⊕	⊕
								N	R	Y B
								VOLTAGE I/P		
⊕	⊕	⊕	⊕	⊕	⊕	⊕	⊕	⊕	⊕	⊕
R1	R2	Y1	Y2	B1	B2	E1	E2		D+	D-
CT SECONDARY					CBCT			µP PORT		
								CONTROL O/P		
								NO	P	NC
⊕	⊕	⊕	⊕	⊕	⊕	⊕	⊕	⊕	⊕	⊕

- **KEY FUNCTIONS OF i.MWM**

KEY	ACTION
	To select the parameter
	To increase the value of the selected parameter
	To decrease the value of the selected parameter
	To reset the fault

- 1) For checking Parameter: Press 'SETTINGS' Key.
- 2) Give the Password '106' OR 'XXX' \* & then press 'SETTINGS' key for the PARA Mode.
- 3) For increasing the value of selected Parameter: Press 'VALUE ▲'key.  
In run mode : If scroll time is 0 sec, then, this key is use to select current, voltage, P.F., Watt,...etc
- 4) For decreasing the value of the selected Parameter: Press 'VALUE ▼'key.
- 5) RESET key the used to reset the faults occurred in i.MWM.



## PARAMETER LIST OF i.MWM FOR 40 TO 500 AMP

Sr. No.	PARAMETER	RANGE	PASSWORD
1	SET CURRENT	40 TO 500 AMP	FACTORY/ENGG.
2	SET UNDER LOAD	0 TO 400 AMP	FACTORY/ENGG.
3	SET EARTH LEAKAGE CURRENT	0.1 TO 25 AMP	FACTORY/ENGG.
4	OVERLOAD CURVE	0 TO 5 Correspond to (0/5/10/15/20/2 Sec.Curve)	ENGG.
5	SPP TRIP TIME	3 to 20 Second	FACTORY/ENGG.
6	UNDERLOAD TRIP TIME	6 to 30 Second	FACTORY/ENGG.
7	BAUD RATE	1 TO 4 Correspond to (9600/19200/38400/57600)	ENGG.
8	SLAVE ID	1 TO 150	FACTORY/ENGG.
9	SCROLL TIME	0 TO 10	FACTORY/ENGG.
10	PHASE REVERSE	ENABLE / DISABLE	FACTORY/ENGG.
11	AUTO RESET	ENABLE / DISABLE	FACTORY/ENGG.
12	SET LOCK ROTOR	3 TO 20 Times of Set Current	ENGG.
13	OVERLOAD DEFINITE TIME	2 TO 900 Second	ENGG.
14	SET UNDERVOLTAGE	160 TO 220 VAC	FACTORY/ENGG.
15	SET OVERVOLTAGE	230 TO 300 VAC	FACTORY/ENGG.
16	OPERATING MODE	PROTECTION	FACTORY/ENGG.
17	CT RATIO	100A/5A to 500A/5A (With step of 50)	ENGG.

### PASSWORD

1. ENGG. PASSWORD : 147 \*
2. FACTORY PASSWORD : 106

- PROGRAMABLE PARAMETER KEY OPERATION

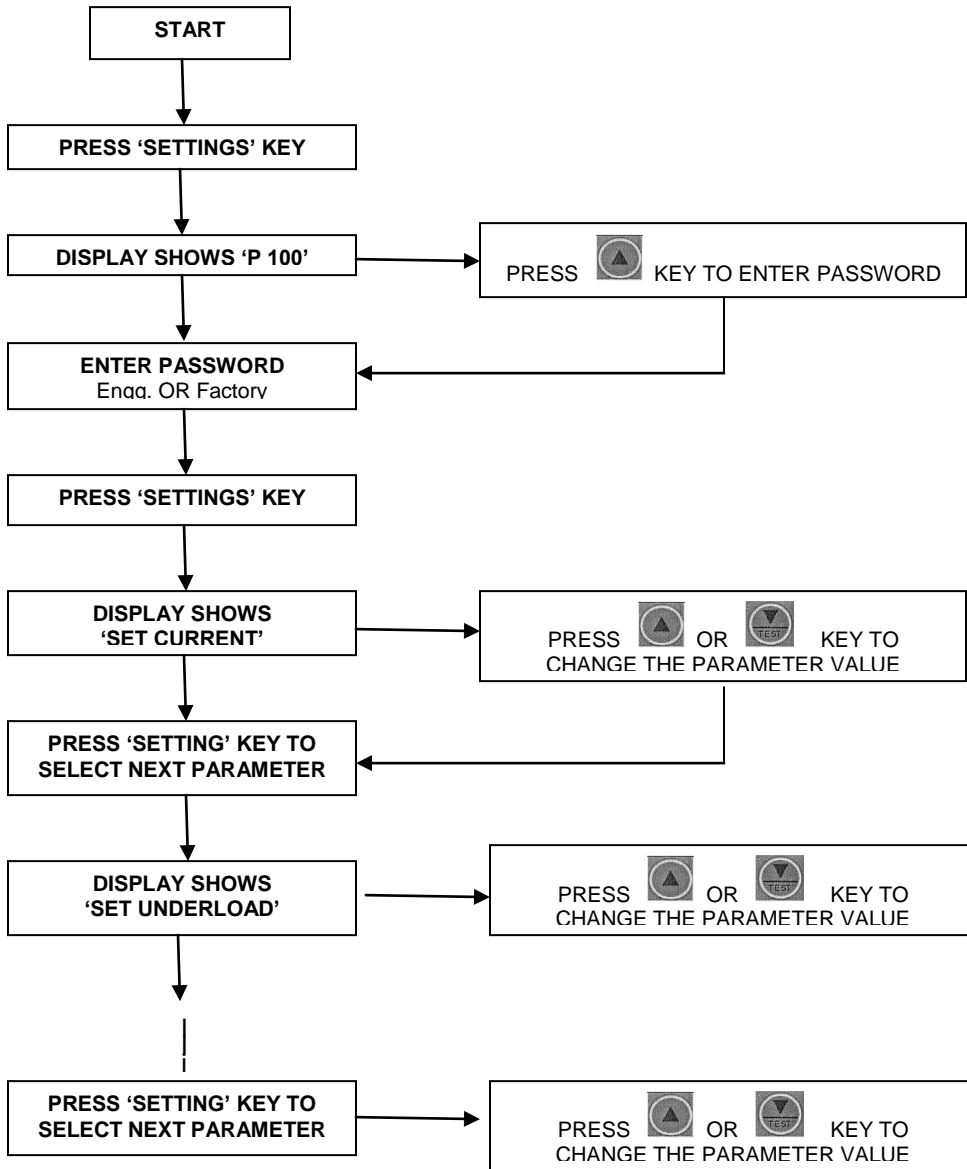

● **RUN DISPLAY**

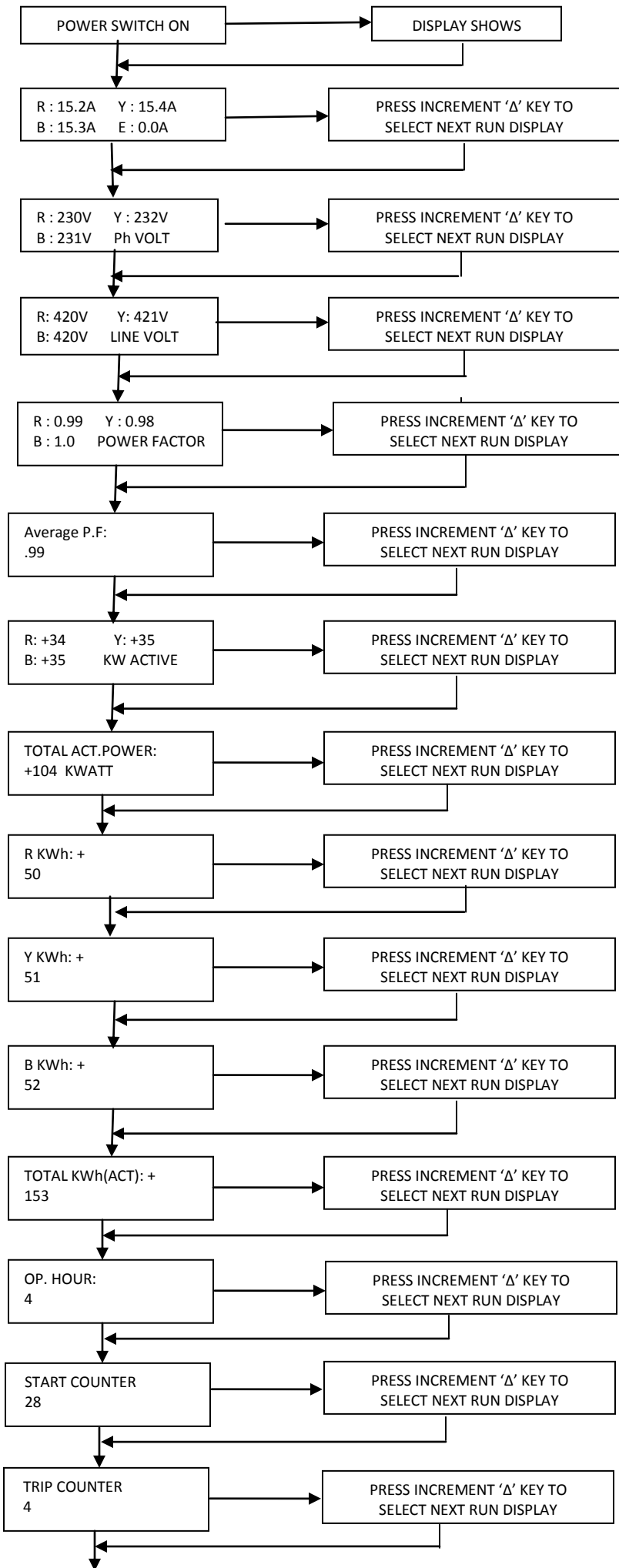

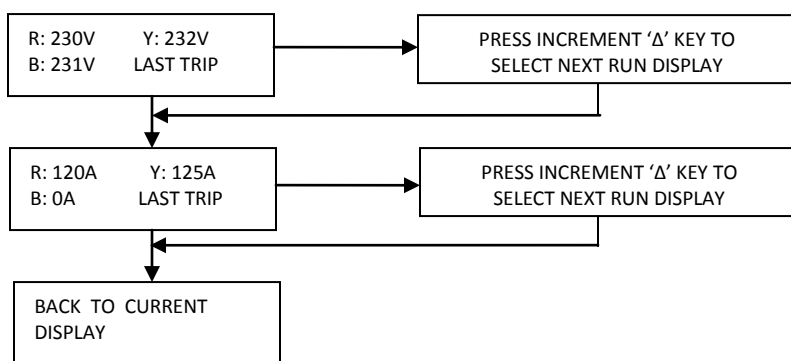

## SETTINGS:

### 1) OVERLOAD TRIP TIME: -

The O/L trip time depends on settable DEFINITE time & the Set O/L CURVE. The O/L trip time is according to the definite time if & only if the O/L curve is '0'. Otherwise O/L trip time is according to settable O/L CURVE.

### 2) LOCK ROTOR: -

The settable range of Lock rotor is 3 to 20 times (i.e. 300% to 2000%) that of the set current. There is no Settable parameter for Short circuit independently, but it is depends on the lock rotor setting, i.e., the short Circuit is equal to the Set lock rotor plus 1 times the set current [i.e. (Set lock rotor + 1) X Set current].

### 3) OPERATING MODE:

PROTECTION:-

- a) In 'Protection' mode, when power supply switched ON, the control output turns ON immediately.
- b) ART time should be 'ZERO'.

### 4) SCROLL TIME:-

The scroll time is settable from 0 to 10 seconds.

- i) When scroll time is given '0' we have to select current, voltage, P.F., kWatt, ..... etc. by the increment '▲' key only.
- ii) When we set the scroll time between 1 to 10 seconds then the run display scrolls automatically after the Selected scroll time.

### 5) C.T.RATIO:-

C.T. Ratio is settable from 100A/5A to 500A/5A (with the step of 50).

- **DO – DETAILS**

Sr.No.	DO No.	DO Description
01	DO	Control Output (P-NO-NC)



## **TRIPPINGS & FAULT MESSAGE :**

### **OVERLOAD:**

If any phase current (R, Y, B) > SET O/L CUR then i.MWM will trip on Over Load according to settable O/L Curve (see page-IT CHARECTERISTICS) or Settable definite time. It will show '**OVER LOAD**' on the LCD Display.

### **UNBALANCE:**

If difference between any two phase current > (SET OL CUR/ 3) then I.MWM will trip with delay of 12 seconds, showing '**UNBALANCE**' on LCD Display.

### **CURRENT SINGLE PHASE PROTECTION:**

Out of R, Y, or B phase if any one phase is absent or OFF then, i.MWM trips

### **OR**

If any one of the thee phase current is  $\neq 1.0A$  then also i.MWM trips with Settable 'SPP TRIP TIME' & LCD Display shows 'CURRENT SPP' on the display.

### **PHASE REVERSE:**

If any two phases (R, Y & B) are interchanged then I.MWM will trips immediately showing "PHASE REVERSAL' on LCD Display.

### **UNDERLOAD:**

If all 3 phases (R, Y, B) < SET UNDELOAD then I.MWM will trip with settable 'UNDERLOAD TIME' delay showing 'UNDER LOAD' on LCD Display.

### **LOCK ROTOR:**

If any one phase current (R, Y, B) > SET O/L CUR X Set Lock Rotor (r), then I.MWM will trip immediately showing 'LOCK ROTOR' on LCD Display.

### **SHORT CKT:**

If any one phase current (R, Y, B) > SET OL CUR X (Set Lock Rotor + 1) then I.MWM will trip Immediately showing 'SHOT CKT' on LCD Display.

### **EARTH FAULT:**

If Earth current > SET EARTH then I.MWM will trip immediately showing 'EARTH FAULT' on LCD Display.

### **OVER VOLTAGE:**

The set over voltage parameter is for the over voltage protection. If any one phase Voltage (R,Y,B) > 'Set Over Voltage' then i.MWM trips immediately showing 'OVER VOLTAGE' on LCD Display.

### **UNDER VOLTAGE:**

The set under voltage parameter is for the under voltage protection. If all three phase Voltage (R,Y,B) < 'Set Under Voltage' then i.MWM trips immediately showing 'UNDER VOLTAGE' on LCD Display.

### **VOLTAGE SPP:**

If any one of Phase is OFF or less than 60VAC then, i.MWM immediately trips & showing "VOLTAGE SPP' on LCD Display.

## LOGIC:

### 1) START Counter :

Each time when current start flowing, the value of the start counter increases by 1.

### 2) TRIP Counter :

The value of trip counter increased by 1 at every time of controlled output trips.

### 3) Control O/P :

- i) After the start command is given 'Control output' relay turn ON immediately.
- ii) After every time the device trips, the 'Control output' relay will turn OFF.

## ABBREVIATIONS USED :

1. SPP : Single Phasing Protection
2. O/L : Over Load
3. ART : Anti Recycle Timer
4. P.F. : Power Factor
5. Ph : Phase
6. CKT : Circuit
7. KW : Kilo Watt
8. KWH : Kilo Watt Hour
9. OP HOUR : Operating Hour

**POWER WIRING DIA FOR i.MWM / 40 to 500 Amp**

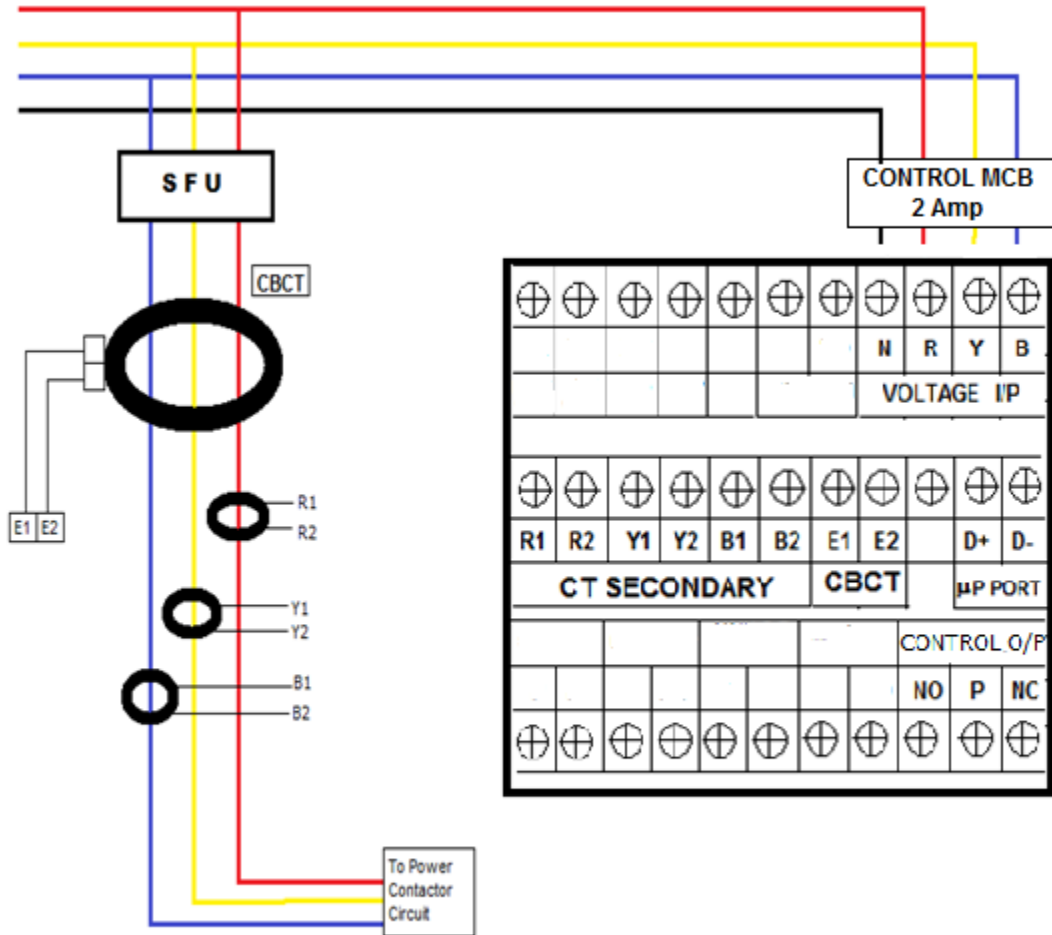

**ADDRESS LIST FOR i.MWM/40-500 Amp.  
(Holding Register)**

Address	Data Type	Parameter / Analog Input	(Range and format)
40035	R	B POWER FACTOR	Value range: 0 to 100, (divide by 100)
40036	R	R kWATT	Value range: 0 to 25000, (divide by 10) –ve kWATT also
40037	R	Y kWATT	Value range: 0 to 25000, (divide by 10) –ve kWATT also
40038	R	B kWATT	Value range: 0 to 25000, (divide by 10) –ve kWATT also
40039	R	R KWH 1	Value range: 0 to 32000 (divide by 100)
40040	R	R KWH2	Value range: above 32000
40041	R	Y KWH 1	Value range: 0 to 32000 (divide by 100)
40042	R	Y KWH2	Value range: above 32000
40043	R	B KWH1	Value range: 0 to 32000 (divide by 100)
40044	R	B KWH2	Value range: above 32000
40045 - 46	--	---	---
40047	R	OPERATING HOURS	---
40048	R	START COUNTER	---
40049	R	TRIP COUNTER	---
40050	R	EARTH CURRENT	Value range: 0 to 260(divide by 10)
40051- 40057	--	SPARE	---
40058	R	Average P.F.	0 to 100, (divide by 100)
40059	R	Total Active Power	Value range: 0 to 32000, (divide by 10) –ve kWATT also
40060 - 85	--	SPARE	--
40086	R	R LINE VOLTAGE	Value range: 0 to 6000, (divide by 10)
40087	R	Y LINE VOLTAGE	Value range: 0 to 6000, (divide by 10)
40088	R	B LINE VOLTAGE	Value range: 0 to 6000, (divide by 10)
40089 - 95	--	SPARE	--
40096	R	TOTAL KWH 1	Value range: 0 to 32000 (divide by 100)
40097	R	TOTAL KWH2	Value range: above 32000
40098 - 103	--	SPARE	--
40104	R	R phase VOLTAGE(Trip status)	Value range: 0 to 3000, (divide by 10)
40105	R	Y phase VOLTAGE(Trip status)	Value range: 0 to 3000, (divide by 10)
40106	R	B phase VOLTAGE(Trip status)	Value range: 0 to 3000, (divide by 10)
40107	R	R phase CURRENT(Trip status)	Value range: 0 to 5000
40108	R	Y phase CURRENT(Trip status)	Value range: 0 to 5000
40109	R	B phase CURRENT(Trip status)	Value range: 0 to 5000

### TRIP / HEALTHY STATUS (Fault Code)

Address	Data Type	Fault Message
40025 <0>	R	HEALTHY
40025 <1>	R	CURRENT O/L
40025 <2>	R	CURRENT SPP
40025 <3>	R	UNDER LOAD
40025 <4>	R	UNBALANCE
40025 <5>	R	LOCK ROTOR
40025 <6>	R	SHORT CKT.
40025 <7>	R	PHASE REVERSE
40025 <8>	R	EARTH FAULT
40025 <9>	R	SPARE
40025<10>	R	SPARE
40025<11>	R	UNDER VOLTAGE
40025<12>	R	OVER VOLTAGE
40025<13>	R	VOLTAGE SPP

### DIGITAL OUTPUT ADDRESS LIST (COIL STATUS)

Address	Data Type	DIGITAL O/P
00001	R	DO

Where, <1> = DO ON, <0> = DO OFF

C.T. RATIO	C.T.
40023<1>	100A/5A
40023<2>	125A/5A
40023<3>	150A/5A
40023<4>	200A/5A
40023<5>	250A/5A
40023<6>	300A/5A
40023<7>	350A/5A
40023<8>	400A/5A
40023<9>	450A/5A
40023<10>	500A/5A